

CONVECTION WARMING DRAWERS

Thermador® | *An American Icon*™



30" Convection Warming Drawer. To be installed with custom front panel or Thermador coordinating front panel (shown).

FEATURES & BENEFITS

The open sides make it easier and more convenient to load and unload

Spacious 2.0 cubic-foot drawer cavity

Convenient touch control panel boasts a digital display and includes an electronic timer, a hot surface indicator, an automatic shut-off feature, and Sabbath mode

400-watt convection heater evenly and quickly heats large stacks of plates

Exclusive 600-watt glass-ceramic heating surface ensures quick and even heating, and is easy to clean

Because the drawer and the door are separate units, it's easy to install with custom cabinetry for a seamlessly integrated look

Telescopic rails feature a telescoping, ball-bearing design for smooth opening and closing that supports up to 55 lbs



WDF30EP
Stainless Steel with Professional handle



WDF30ES
Stainless Steel with Masterpiece handle



WDF30EB
Black with Masterpiece handle

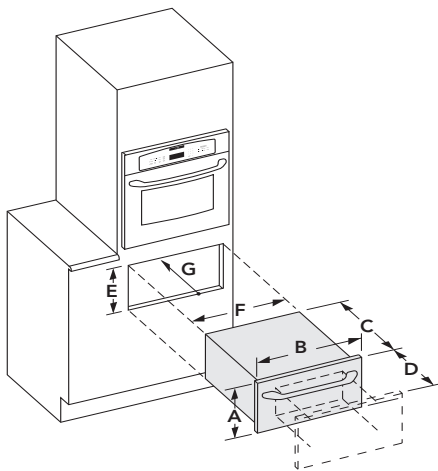

SKU	WDC30E
Cabinet Size	30
Warming Drawer Wattage	120 Volts, 2 Wire 60 Hz, w/ gnd. 930 W.
Amps	Single Phase A.C., 20 Amps
Approx. Shipping Weight	62
Coordinating Front Panels (Sold Separately)	
Stainless Steel With Professional Handle	WDF30EP
Stainless Steel With Masterpiece Handle	WDF30ES
Black	WDF30EB

Model No.	Overall Dimensions				Cutout Dimensions*			Interior Drawer Usable Space	Custom Panel Dimensions	
	A	B	C **	D	E	F	G	Cu. Ft.	H	W
WDC30E	11 ¹ / ₄	29 ³ / ₄	22 ³ / ₄	22	10	28 ¹ / ₂	24	2.0	11 ¹ / ₄	29 ³ / ₄

Notes: All height, width and depth dimensions are shown in inches. *Please refer to installation instructions prior to making cutout. Installation instructions are available at www.thermador.com. **Measured from cabinet face. Add 3¹/₈" for distance from drawer handle to cabinet face.

1 800 735 4328 | WWW.THERMADOR.COM | 5551 MCFADDEN AVENUE, HUNTINGTON BEACH, CA 92649