

24" Evolution 800 Plus Series Dishwasher SHE68E15UC



Features and Benefits

Appearance

- Stainless Steel TallTub w/ Lifetime Warranty on Rust-Through
- 6 Wash Cycles and 5 Options

Quietness

- Virtually Silent: 40 dBA
- Quietest Dishwasher in the U.S.
- Two Pump Motor System Minimizes Noise and Vibration
- Solid Molded Base Contains Sound and Prevents Leaks

Efficiency

- 180 kwh/yr - Exceeds Energy Star® Guidelines
- Most Efficient Dishwasher in the U.S.
- EcoAction™ Option - Bosch Exclusive Feature Reduces Energy Usage by up to 25%
- EcoSense™ Reduces Energy Usage by up to 20%
- Half Load Option for Small or Lightly Soiled Loads
- Flow-Through Water Heater™
- Triple Filtration System

Safety

- AquaStop® Plus 4-Part Leak Protection Works 24/7
- PerfectDoor™ Keeps Dishwasher Door at Angle You Want
- Sanitize Option eliminates bacteria and enhances drying results
- SaniDry™ Hygienic Condensation Drying
- Concealed Heating Element - No Melting of Plastics

Capacity

- 15 Place Setting Capacity



Notes: All height, width and depth dimensions are shown in inches. *Please refer to installation instructions prior to making cutout. BSH reserves the absolute and unrestricted right to change product materials and specifications, at any time, without notice. Consult the product's installation instructions for final dimensional data and other details. Applicable product warranty can be found in a accompanying product literature or you may contact your account manager for further details.

For more information on our entire line of products, go to boschappliances.com or call 1-800-944-2904.
Copyright ©2009 BSH Home Appliances Corporation. All rights reserved. Bosch is a registered trademark of Robert Bosch GmbH.

Litho Date: 05/2009



24" Evolution 800 Plus Series Dishwasher SHE68E15UC

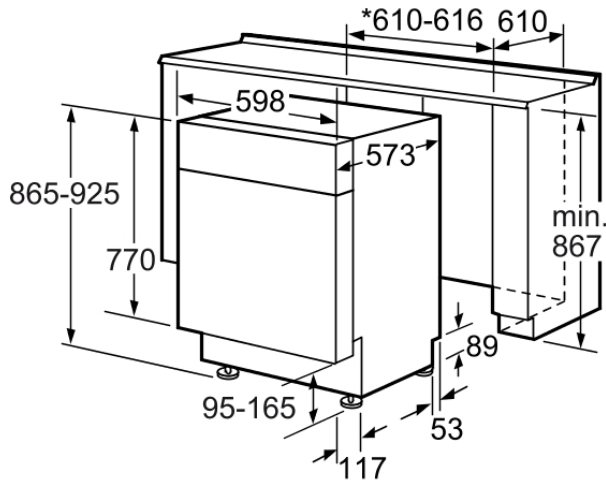

* 600 without decor strips

Measurements in mm

Features

UPC code	825225868361
Main colour of product	Stainless steel
Installation Type	Build-under
Panel ready	Not possible
Alternative colors available	
Silence level (dBA)	40
Watts (W)	1300
Current (A)	12
Volts (V)	120
Frequency (Hz)	60
Total annual energy consumption (kWh)	180
Energy Star® qualified	Yes
Plug type	120V-3 prong
Power cord length (in)	
Length outlet hose (in)	55 1/8 "
Length inlet hose (in)	
Required cutout size (HxWxD) (in)	34 1/4" x 24 " x 24 "
Overall appliance dimensions (HxWxD) (in)	34 1/16 " x 23 9/16 " x 22 9/16 "
Product packaging dimensions (HxWxD) (in)	36.22 x 24.80 x 26.77
Net weight (lbs)	107
Gross weight (lbs)	112
Adjustable feet	Yes
Tub material	Stainless steel
Tub type	
ADA Compliant	No
Number of place settings	14

Technical Specification

Leak Protection System	AQUASTOP PLUS with AQUASTOP Hose
ChildLock	Childlock appliance
Water softener	Yes
Top basket type	high
Adjustable upper rack	Rackmatic 3-stage
Shelf Racks in Top Basket	
Upper rack cup shelf	2 x foldable cup shelves
Bottom basket type	high
Bottom basket Inserts	2
3rd Rack	yes
Silverware basket	Standard
Optional accessories	SGZ1010, SGZ2014, SMZ5000, SMZ5002, SMZ5100

Notes: All height, width and depth dimensions are shown in inches. *Please refer to installation instructions prior to making cutout. BSH reserves the absolute and unrestricted right to change product materials and specifications, at any time, without notice. Consult the product's installation instructions for final dimensional data and other details. Applicable product warranty can be found in a accompanying product literature or you may contact your account manager for further details.

For more information on our entire line of products, go to boschappliances.com or call 1-800-944-2904.
Copyright ©2009 BSH Home Appliances Corporation. All rights reserved. Bosch is a registered trademark of Robert Bosch GmbH.

Litho Date: 05/2009

