

Evolution™ 500 Series Dishwasher SHE53L0



BOSCH
Invented for life



Can a dishwasher make your house a **better** place to live?

Absolutely, if it's a Bosch. Bosch dishwashers are the only ones to offer unique combination of nearly silent operation, powerful features that leave dishes sparkling, intelligent functions that work around your lifestyle and an efficient operation that saves both water and electricity. All wrapped in a contemporary design that's as beautiful as it is functional.

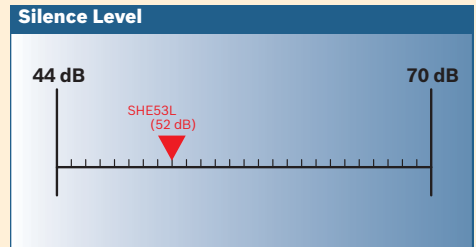

Class-leading Quietness

Bosch dishwashers are the quietest. With a suspended two-pump motor system, vibrations and noise are drastically reduced. And with heavy-duty bitumen, coated metal and cotton fiber sheet insulation, the noise is basically buried.



ENERGY STAR® Qualified and NSF Certified

Proving once again that Bosch is committed to efficiency, all of our dishwashers already exceed the 2007 ENERGY STAR® requirements. They also boast NSF certification for 9 out of 12 wash cycles, ensuring your dishes are 99.99% bacteria-free at the end of each cycle.



SENSOTRONIC®

An advanced scanning eye examines the level of soil in the wash water and automatically deletes a secondary fresh-water fill if not needed, saving you time and money while cutting energy usage by 20%.



AQUASTOP™

Leaks are contained before they ever touch the floor with this Bosch exclusive. It monitors the level of water in the base of the machine and automatically shuts down operation in the highly unlikely event of a leak.



SHE53L05
Painted Stainless Steel

SHE53L02
White



SHE53L06
Black

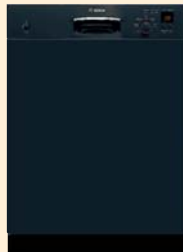

Model/Features

Evolution 500 Series Dishwasher SHE53L0

- **AQUASTOP™** Leak Protection System
- Stainless Steel **TALLTUB™**
- Two-Pump Motor System
- Suspension Motor™
- Triple Filtration System
- Flow-Through Water Heater™
- Five-Level Wash
- Condensation Drying
- Extra-Tall Item Sprinkler
- Nylon Coated Racks
- NSF Certified Units and Cycles
- Electronic Controls
- 2007 ENERGY STAR® Qualified
- 52 dB Silence Rating
- Cotton padding insulation
- Bituminous Layer

5 Wash Cycles

- Power Scrub Plus (161°F)*
- Regular Wash (140°F)*
- Delicate/Economy Wash (120°F)*
- **QUICKWASH™**
- Rinse & Hold

Wash Options

- Delay Start
- Half Load

Wash System

- **SENSOTRONIC®**

Upper Rack

- Manual Adjustability
- 2 Half Flip-Down Rows
- 2 Cup Shelves

Lower Rack

- Silverware Basket
- Silverware Basket Cover

Display

- LED Display
- Multi Function LED
- Sanitized Indicator Light
- Rinse Aid Indicator Light

Other

- Standard Dispenser
- Auto Close Door
- End of Cycle Sound

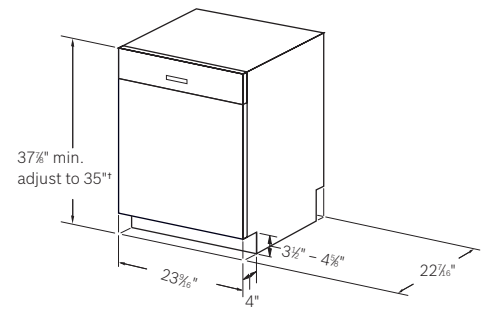

* Maximum height of 36" possible with toe-kick from cabinet supplier.

Dimensions for planning only. For details, see installation manual, or visit www.boschappliances.com. Specifications subject to change without notice.

*NSF Certified

Copyright ©2006 BSH Home Appliances Corporation. All rights reserved. Bosch is a registered trademark of Robert Bosch GmbH.

Dishwasher Warranty: 1 year parts and labor, 2 years parts, 5 years on all electronic components (parts only), 5 years on racks (part only), lifetime warranty against rust-through on tub. Certain limitations apply; See manufacturer's limited warranty for details.

BSH reserves the absolute and unrestricted right to change product materials and specifications, at any time, without notice. Consult the product's installation instructions for final dimensional data and other details. Applicable product warranty can be found in accompanying product literature (or you may contact your account manager for further details).

