

EVOLUTION™ 300 Series SHE33M0_UC

Dishwasher Spec Sheet



BOSCH

Invented for life



SHE33M05UC



J.D. Power and Associates ranked Bosch "Highest in Customer Satisfaction with Dishwashers."

Features & Benefits

- Visible Control Panel
- 3 Wash Cycles
- Stainless Steel TALLTUB
- ECOSENSE™ Wash Management System
- AQUASTOP® Leak Protection
- Level Dishwasher From Front

Dimensions:*

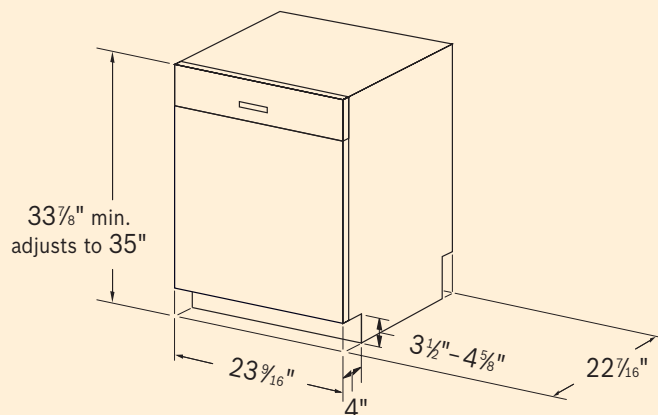

SHE33M0_UC

Type	Dishwasher
Color Options	
Black	SHE33M06UC
White	SHE33M02UC
Stainless Steel w/black control	SHE33M05UC
Fascia Panel Color	Black
Stainless Steel TALLTUB	•
Two-Pump Motor System	•
Suspension Motor	•
Triple Filtration System	•
Flow-Through Water Heater	•
Five Level Wash	•
Condensation Drying	•
Nylon Coated Racks	•
NSF Certified Cycles	•
Electronic Controls	•
Silence Rating	57 dBA
Wash Cycles	3
Power Scrub Plus	•
Regular Wash	•
Rinse & Hold	•
ECOSENSE™	•
Upper Rack	Platinum Standard
Adjustability	Manual
Flip Tines Upper Rack	1 Half Flip Down Rows
Cup Shelves	2
Lower Rack	Standard
Silverware Basket	Standard
Silverware Basket Cover	Yes
Place Setting Capacity	14
LED	•
Sanitized Indicator Light	•
Rinse Aid Indicator Light	•
AQUASTOP® Leak Protection	•
CHILDLOCK	Control
Est. Yearly Energy Consumption	259 kWh
ENERGY STAR® Qualified	•
Maximum Amp Draw	12A
Power Requirements	120V AC, 60Hz, 15A
Cutout (HxWxD)	34" x 24" x 22 7/16"
Level Rear Legs From Front	•
Power Cord Accessory Available	•



Dishwashers are UL approved. Notes: All height, width and depth dimensions are shown in inches. *Please refer to installation instructions prior to making cutout. BSH reserves the absolute and unrestricted right to change product materials and specifications, at any time, without notice. Consult the product's installation instructions for final dimensional data and other details. Applicable product warranty can be found in accompanying product literature or you may contact your account manager for further details.

Bosch received the highest numerical score with dishwashers in the proprietary J.D. Power and Associates 2006 Major Home Appliance StudySM. Study based on 12,656 total responses measuring 11 brands and measures opinions of consumers during the previous 24 months. Proprietary study results are based on experiences and perceptions of consumers surveyed in July and September 2006. Your experiences may vary. Visit jdpower.com.

For more information on our entire line of products, go to boschappliances.com or call 1-800-944-2904.

Copyright ©2007 BSH Home Appliances Corporation. All rights reserved. Bosch is a registered trademark of Robert Bosch GmbH.

