

PROFESSIONAL SERIES DELUXE SINGLE OVEN



Professional Series Deluxe stainless steel single oven with electronic display and True Convection.

FEATURES & BENEFITS

Metal knobs, professional handles and analog clock coordinate with Thermador's Professional Series

Graphic displays feature meat probe temperature, timer, delayed cooking and preheat monitor

Superfast preheat cycle heats oven cavity in about 7 minutes

Massive 4.7 cu. ft. oven cavity

Concealed bake element for enlarged capacity

Exclusive, dishwasher-safe, professional-quality rotisserie supports up to 12 lbs.

Totally recessed 5,000-watt, 12 pass MaxBroil™ element offers the most powerful and even heating

New True Convection baffle system directs heat precisely and evenly

New Speed Convection mode reduces cooking time for frozen foods up to 30%

Ball bearing full-extension telescopic rack

SKU	POD301
Size	30"
Type	Single
Color-Stainless Steel	POD301
Cavity Size*	4.7 cu. ft.
Control	Professional-Style
Display	Blue graphic
MAIN FEATURES	
Professional Design	■
True Convection	■
Speed Convection	■
Rotisserie	■
MaxBroil	■
Convection Broil	■
Max Convection Broil	■
Convection Roast	■
Bake, Roast	■
Broil	■
Warm	■
Fast Preheat	■
Dehydrate	■
Meat Probe	■
Self-Clean	■
Self-Clean Rack Supports	■
Full Access® Telescopic Racks**	1
Professional-Style Racks	2
Porcelain Broiler Pan	■
Halogen Lighting Per Cavity	4
Concealed Bake Element	■

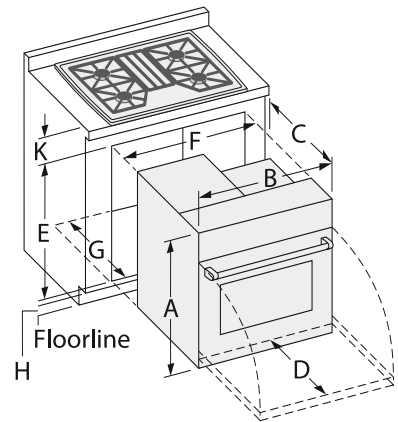

Model No.	Overall Dimensions				Cutout Dimensions***					Door Handle Projection	Dual-Rated 120/208-240V, 4 Wire, 60 Hz.	Amps
	A	B	C	D	E	F	G	H	K			
PO301	29 ¹ / ₁₆	29 ³ / ₄	23 ⁷ / ₈	22	28 ¹ / ₄	28 ¹ / ₂	24	4 ³ / ₄ min	3	4 ¹ / ₁₆	■	30

BSH reserves the absolute and unrestricted right to change product materials and specifications, at any time, without notice. Consult the product's installation instructions for final dimensional data and other details. Applicable product warranty can be found in accompanying product literature (or you may contact your account manager for further details). **Notes:** All height, width and depth dimensions are shown in inches. *According to AHAM standards. **Available as separate accessory TLSCPRCK30. ***Please refer to installation instructions prior to making cutout.