

PROFESSIONAL COOKTOP ELECTRIC GRIDDLE

Thermador | *An American Icon*



Titanium-surface electric griddle
Also available on PCD484EE cooktop
and PRD484EE Pro Grand® range.

FEATURES & BENEFITS

Powerful, 8-pass, 1600 watt electric element transfers and radiates thermo heat across the entire griddle for even heat distribution.

Powerfully Quiet® electrical element that is faster and safer compared to gas ignition systems.

Precision thermostat is located at the top of the griddle to accurately control the temperature.

Non-stick, non-rust titanium surface is easy to clean and dishwasher safe.

State-of-the-art "black coating" under the griddle plate creates maximum heat absorption for faster cooking performance.

The griddle element is fully insulated and is inset in an aluminized steel tray for controlling and directing heat into the griddle plate.

Easy installation and stand alone unit. Perfect accompaniment to Professional Series range or cooktop.

SKU	PCD24EE
Size	24"
Type	Electric Griddle
Color	Stainless Steel

GENERAL INFORMATION	
220 Volts, 3 Prong Plug, 60 Hz, Single Phase A.C.	30 Amps
Fuel Type	NG
Approximate Shipping Weight (lbs.)	150
LP Converter Orifices	N/A

ADDITIONAL ACCESSORIES	
12" Low Back Guard	GP24LBS
Island Trim***	GP24ITS
24" Griddle Cover	PC24CVRGE
24" Chopblock	PC24CHPBLK
Black Knob Accessory Kit	KNOBBLKHC
Blue Knob Accessory Kit	KNOBBLUHC

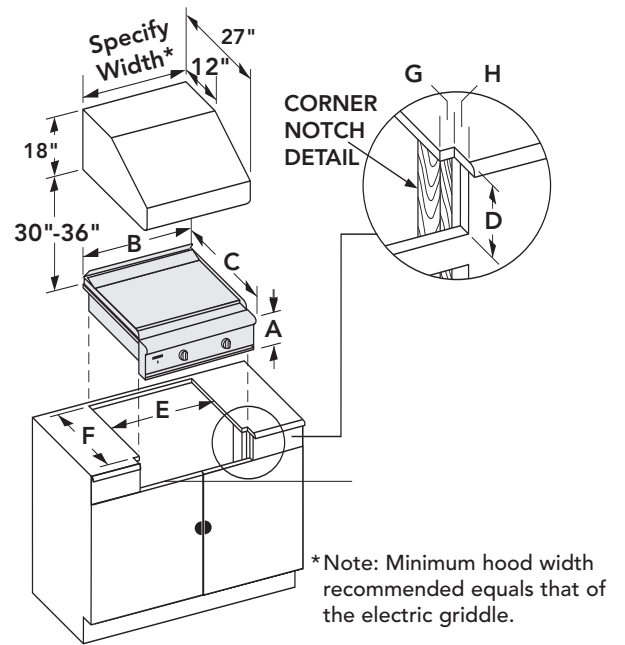

Model No.	BTU/hr Max.	Overall Dimensions			Cutout Dimensions**				
		A	B	C	D	E	F (min.)	G	H
PCD24EE	N/A	8 ¹ / ₈	24 ³ / ₄	26 ¹ / ₂	7 ¹³ / ₁₆	24	22 ¹¹ / ₁₆	3/ ₈	2

BSH reserves the absolute and unrestricted right to change product materials and specifications, at any time, without notice. Consult the product's installation instructions for final dimensional data and other details. Applicable product warranty can be found in accompanying product literature (or you may contact your account manager for further details). **Notes:** All height, width and depth dimensions are shown in inches. *According to AHAM standards. **Please refer to installation instructions prior to making cutout.

1 800 735 4328 | WWW.THERMADOR.COM | 5551 MCFADDEN AVENUE, HUNTINGTON BEACH, CA 92649