

Evolution™ 300 Series

Free-Standing Electric Range Spec Sheet HES3023U



BOSCH
Invented for life



Features & Benefits

- Recommended Companion to Ascenta Dishwasher or other Bosch 300 Series Products.
- Design Fits to Bosch Family Look.
- Power Element – Quick Heating with Powerful 2,500 Watt Element.
- Dual Element Offers the Capability to use Multiple Pan Sizes.
- Hidden Bake Element for Improved Cleanability.
- Two Racks and Six Different Rack Positions Adjust for All Cooking Needs.
- Wide View Oven Window – Extra large Window Provides Easy Viewing of Your Food.
- Self Clean Cycle Saves Time. Quickly and Easily Cleans your Oven.
- Large Cavity with 5.4 cu.ft. Easily Accommodates Large Dishes and Offers Multiple Rack Cooking.
- Knobs Feature a Safety “Push to Turn” System – Makes it Harder for Children to operate the Range.

Model

HES3023U	White
-----------------	-------

Oven Specifications

Cavity Dimensions	5.4 cu.ft.
Type of Oven Lights	40 Watt Incandescent
# of Oven Lights	1
Standard Racks	2
Rack Positions	6
Bake Wattage	3,500 Watts
Broil Wattage	3,600 Watts
Concealed Bake Element	•
Bake	•
Variable Broil (HI or LO)	•
Self-Clean	•
# of Cooking Modes	3
Auto Door Lock During Cleaning	•

Oven Control Functions

Countdown Timer	•
Clock	•
Delayed Bake	•
Auto Shutoff	•
Panel Lock	•
Storage Drawer	•

Cooktop Specifications

Left Front Element	6/9" 2,500 Watts
Left Rear Element	6" 1,200 Watts
Right Front Element	6/9" 2,500 Watts
Right Rear Element	6" 1,200 Watts
Cooktop Material	Ceramic Glass
Cooktop Color	Black
Backguard Color	White

Technical Details

120 / 240 or 120 / 208 Volts; 4 Wire;	•
60 Hz; Single Phase	
Amps (dedicated circuit)	40
Approval	UL, CSA

Dimensions:

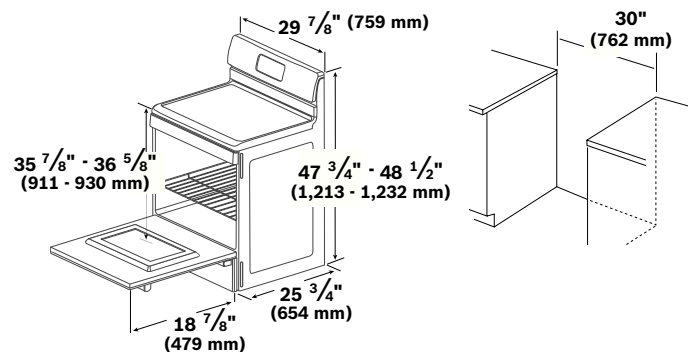

Notes: All height, width and depth dimensions are shown in inches. Please refer to installation instructions prior to making cutout. BSH reserves the absolute and unrestricted right to change product materials and specifications, at any time, without notice. Consult the product's installation instructions for final dimensional data and other details. Applicable product warranty can be found in accompanying product literature or you may contact your account manager for further details.

For more information on our entire line of products, go to boschappliances.com or call 1-800-944-2904.

Copyright ©2009 BSH Home Appliances Corporation. All rights reserved. Bosch is a registered trademark of Robert Bosch GmbH.