

MASTERPIECE DELUXE

36" ELECTRIC COOKTOP WITH TOUCH CONTROL
AND BRIDGE ELEMENT
CET366FS

Thermador® | *An American Icon*™

FEATURES & BENEFITS

Includes a bridge element with a dual element — a Thermador exclusive.

Touch controls with blue light illumination are easy to use and offer a sleek, modern design.

Newly designed control panel coordinates with all Thermador Masterpiece™ Series appliances.

This cooktop is easy to clean and can be installed to fit flush with your kitchen countertop.

Thermador's triple element offers the maximum in cooking flexibility.

The Keep Warm option on every element helps you prepare multiple-course meals.



Notes: All height, width and depth dimensions are shown in inches. Solid surface countertops require special cutout size. Please refer to installation instructions prior to making cutout. Installation instructions are available at www.thermador.com.

1 800 735 4328 | WWW.THERMADOR.COM | 5551 MCFADDEN AVENUE, HUNTINGTON BEACH, CA 92649

©2008 BSH HOME APPLIANCES CORPORATION, ALL RIGHTS RESERVED

LITHO DATE: 02/2008



MASTERPIECE DELUXE
36" ELECTRIC COOKTOP WITH TOUCH CONTROL
AND BRIDGE ELEMENT
CET366FS

Thermador® | *An American Icon*™

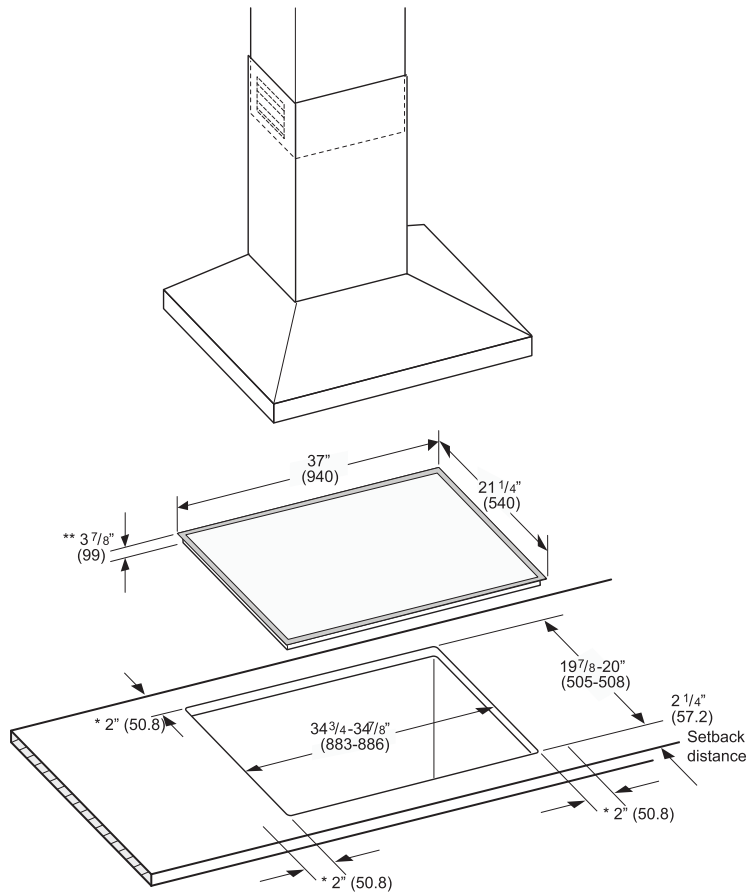

* minimum distance from cutout to the wall
 ** installed depth

SKU	CET366FS
MAIN FEATURES	
Power /Amps	240 V, 3 wire, 60Hz / 50 Amps
Child Lock	Yes
Auto Shut-Off Timer	No
Keep Warm Function	Yes
Number of Cooking Zones	10
Triple Elements	1
Dual Elements	2
Fast PreHeat	No
Sensor Dome™	No
Controls	Touch control with blue illumination
Trim Design	Full Stainless Steel frame
ELEMENT TYPE (watts)	
Front Left	1100-2500 W
Rear Left	1200 W
Center	1050-2200-3080 W
Rear Right	600-1700 W
Front Right	700-1700 W
Total KW (max)	10800 W
ELEMENT SIZES (inches)	
Front Left	6"-9"
Rear Left	6"
Center	6"-8"-12"
Rear Right	7"
Front Right	5"-7"

Notes: All height, width and depth dimensions are shown in inches. Solid surface countertops require special cutout size. Please refer to installation instructions prior to making cutout. Installation instructions are available at www.thermador.com.

1 800 735 4328 | WWW.THERMADOR.COM | 5551 MCFADDEN AVENUE, HUNTINGTON BEACH, CA 92649

©2008 BSH HOME APPLIANCES CORPORATION, ALL RIGHTS RESERVED

LITHO DATE: 02/2008

