

MASTERPIECE DELUXE
30" ELECTRIC COOKTOP WITH TOUCH CONTROL
CET304FS

Thermador® | *An American Icon*™

FEATURES & BENEFITS

Touch controls with blue light illumination are easy to use and offer a sleek, modern design.

Newly designed control panel coordinates with all Thermador Masterpiece™ Series appliances.

This cooktop is easy to clean and can be installed to fit flush with your kitchen countertop.

Thermador's triple element offers the maximum in cooking flexibility.

The Keep Warm option on every element helps you prepare multiple-course meals.



Notes: All height, width and depth dimensions are shown in inches. Solid surface countertops require special cutout size. Please refer to installation instructions prior to making cutout. Installation instructions are available at www.thermador.com.

1 800 735 4328 | WWW.THERMADOR.COM | 5551 MCFADDEN AVENUE, HUNTINGTON BEACH, CA 92649

©2008 BSH HOME APPLIANCES CORPORATION, ALL RIGHTS RESERVED

LITHO DATE: 02/2008



MASTERPIECE DELUXE
30" ELECTRIC COOKTOP WITH TOUCH CONTROL
CET304FS

Thermador® | *An American Icon*™

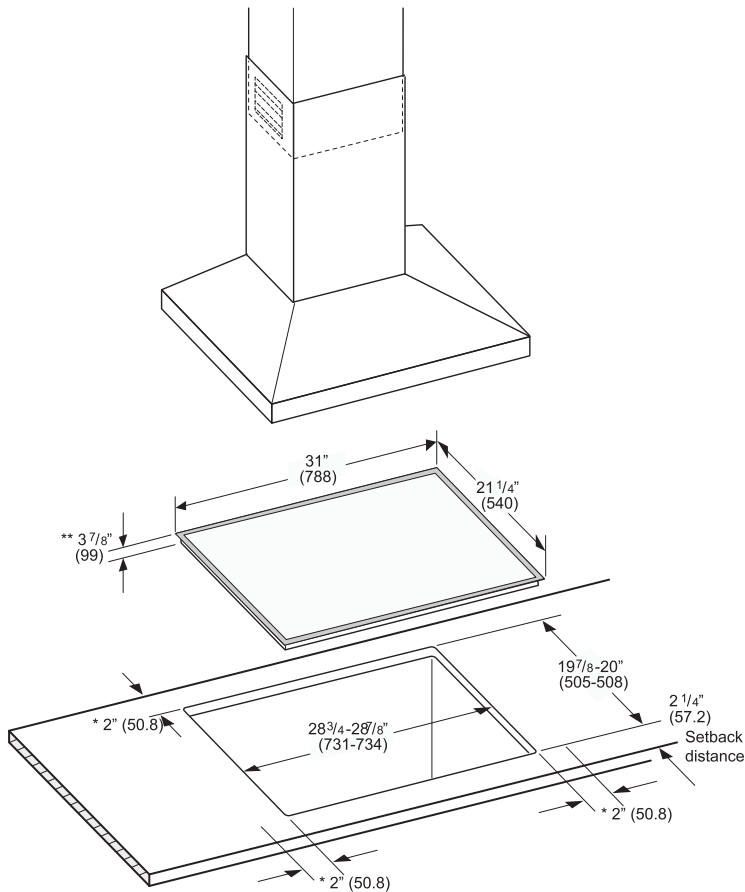

* minimum distance from cutout to the wall
 ** installed depth

| | |
|-------------------------------|--------------------------------------|
| SKU | CET304FS |
| MAIN FEATURES | |
| Power /Amps | 240 V, 3 wire, 60Hz / 40 Amps |
| Child Lock | Yes |
| Auto Shut-Off Timer | No |
| Keep Warm Function | Yes |
| Number of Cooking Zones | 8 |
| Triple Elements | 1 |
| Dual Elements | 2 |
| Fast PreHeat | No |
| Sensor Dome™ | No |
| Controls | Touch control with blue illumination |
| Trim Design | Full Stainless Steel frame |
| ELEMENT TYPE (watts) | |
| Front Left | 1200 W |
| Rear Left | 1100-2500 W |
| Rear Right | 900-1600-2500 W |
| Front Right | 700-1700 W |
| Total KW (max) | 7900 W |
| ELEMENT SIZES (inches) | |
| Front Left | 6" |
| Rear Left | 6"-9" |
| Rear Right | 5"-7"-9" |
| Front Right | 5"-7" |

Notes: All height, width and depth dimensions are shown in inches. Solid surface countertops require special cutout size. Please refer to installation instructions prior to making cutout. Installation instructions are available at www.thermador.com.

1 800 735 4328 | WWW.THERMADOR.COM | 5551 MCFADDEN AVENUE, HUNTINGTON BEACH, CA 92649

©2008 BSH HOME APPLIANCES CORPORATION, ALL RIGHTS RESERVED

LITHO DATE: 02/2008

