

MASTERPIECE
36" ELECTRIC COOKTOP
CEM365FS

Thermador® | *An American Icon*™

FEATURES & BENEFITS

High quality, robust, metal knobs are durable and easy to use.

Newly designed control panel coordinates with a suite of Thermador Masterpiece™ Series appliances.

This cooktop is easy to clean and can be installed to fit flush with your kitchen countertop.



Notes: All height, width and depth dimensions are shown in inches. Solid surface countertops require special cutout size. Please refer to installation instructions prior to making cutout. Installation instructions are available at www.thermador.com.

1 800 735 4328 | WWW.THERMADOR.COM | 5551 MCFADDEN AVENUE, HUNTINGTON BEACH, CA 92649

©2008 BSH HOME APPLIANCES CORPORATION, ALL RIGHTS RESERVED

LITHO DATE: 02/2008



MASTERPIECE
36" ELECTRIC COOKTOP
CEM365FS

Thermador® | *An American Icon*™

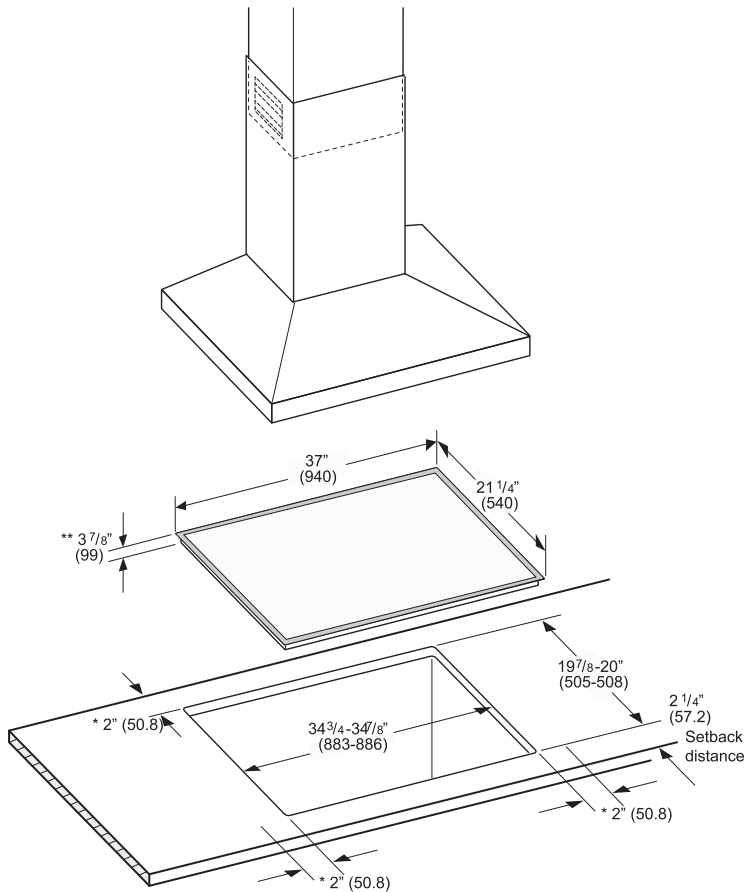

* minimum distance from cutout to the wall
 ** installed depth

SKU	CEM365FS
MAIN FEATURES	
Power /Amps	240 V, 3 wire, 60Hz / 40 Amps
Child Lock	No
Auto Shut-Off Timer	No
Keep Warm Function	No
Number of Cooking Zones	7
Dual Elements	2
Fast PreHeat	No
Sensor Dome™	No
Controls	Manual
Knob Material	Die-cast metal
Trim Design	Full Stainless Steel frame
ELEMENT TYPE (watts)	
Front Left	750-2200 W
Rear Left	1200 W
Center	1100-2500W
Rear Right	1800 W
Front Right	1800 W
Total KW (max)	9500 W
ELEMENT SIZES (inches)	
Front Left	5"-8"
Rear Left	6"
Center	6"-9"
Rear Right	7"
Front Right	7"

Notes: All height, width and depth dimensions are shown in inches. Solid surface countertops require special cutout size. Please refer to installation instructions prior to making cutout. Installation instructions are available at www.thermador.com.

1 800 735 4328 | WWW.THERMADOR.COM | 5551 MCFADDEN AVENUE, HUNTINGTON BEACH, CA 92649

©2008 BSH HOME APPLIANCES CORPORATION, ALL RIGHTS RESERVED

LITHO DATE: 02/2008

