

SPECS / DIMENSIONS



CEM365CB

36" CEM BLACK CERAMIC ELECTRIC MECHANICAL KNOBS COOKTOP

PRINT

GENERAL INFORMATION

Approximate Shipping Weight (LBS.)	45
Access. Griddle (AEGRIDDL)	✓
Front Left Element (Watts)	1200
Front Right Element (Watts)	1800 Bridge
Rear Left Element (Watts)	750/2200
Rear Middle Element (Watts)	1100/2500
Rear Right Element (Watts)	1800 Bridge

TECHNICAL INFORMATION

208-240 Volts, 3 Wire, 60 Hz	✓
AMPS	40

DIMENSIONS (INCHES)

Overall Dimensions - A	37
Overall Dimensions - B	21 3/8
Overall Dimensions - C	3 5/8
Cutout Dimensions* D	34 3/4- 34 7/8
Cutout Dimensions* E	19 7/8- 20
Cutout Width (CVS Downdraft)	34 3/4
Cutout Width (UCV Downdraft)	34 3/4
Cutout Depth (CVS Downdraft)	22 7/16
Cutout Depth (UCV Downdraft)	22 1/8
Overall Width (CVS Downdraft)	37
Overall Width (UCV Downdraft)	37
Overall Depth (CVS Downdraft)	23 3/4
Overall Depth (UCV Downdraft)	23 7/8
Set Back Min. (CVS Downdraft)	2 1/2
Set Back Min. (UCV Downdraft)	2 1/2

Diagrams

Comprehensive Countertop Cutout with Downdraft (UCV)

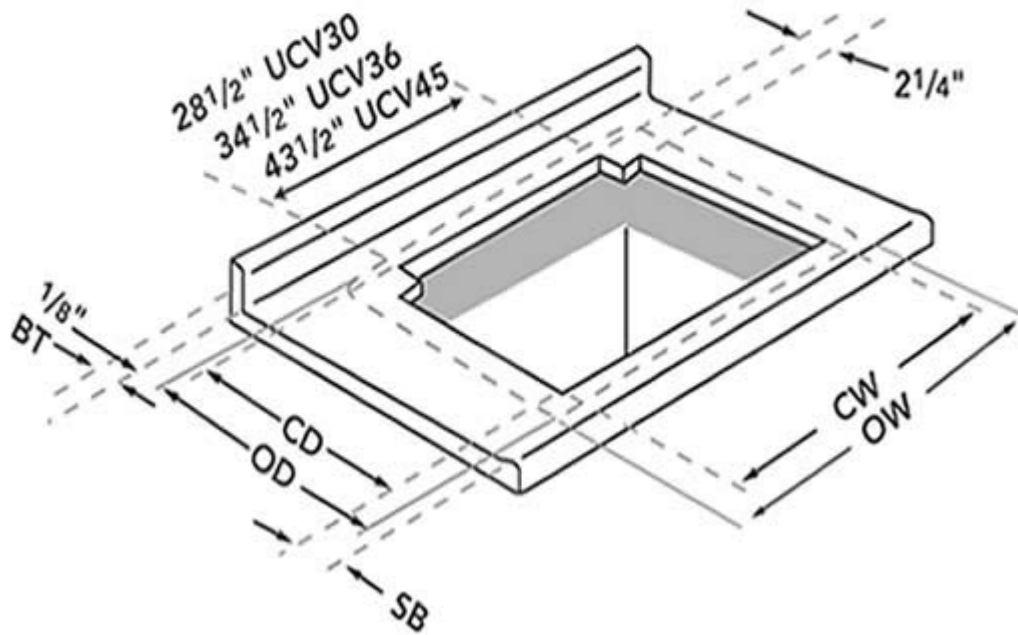

Comprehensive Countertop Cutout with Downdraft (CVS)

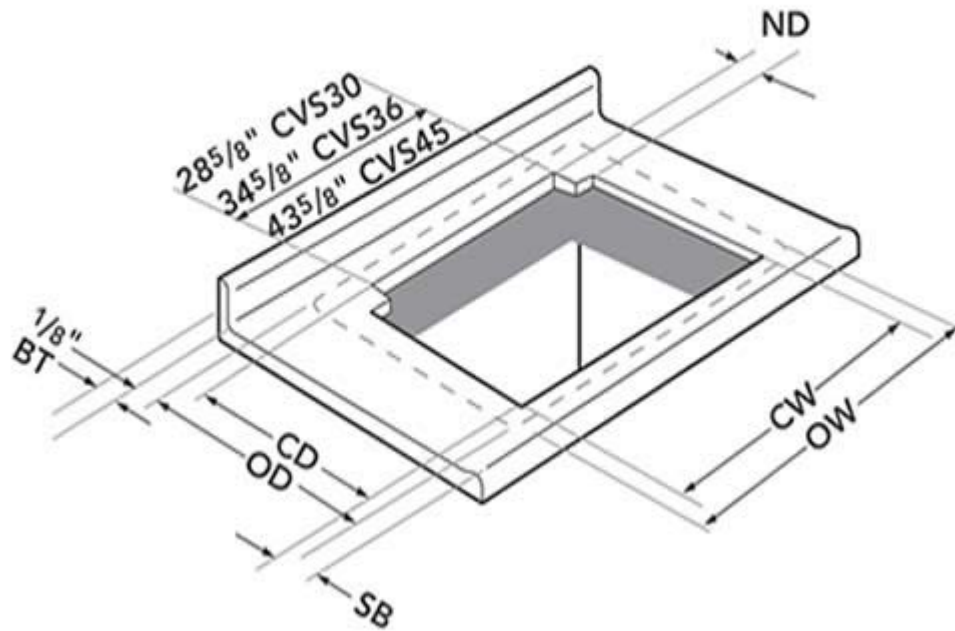

Ceramic Electric Cooktop Cutout Shown with C301 Single Oven and HDW Chimney Hood

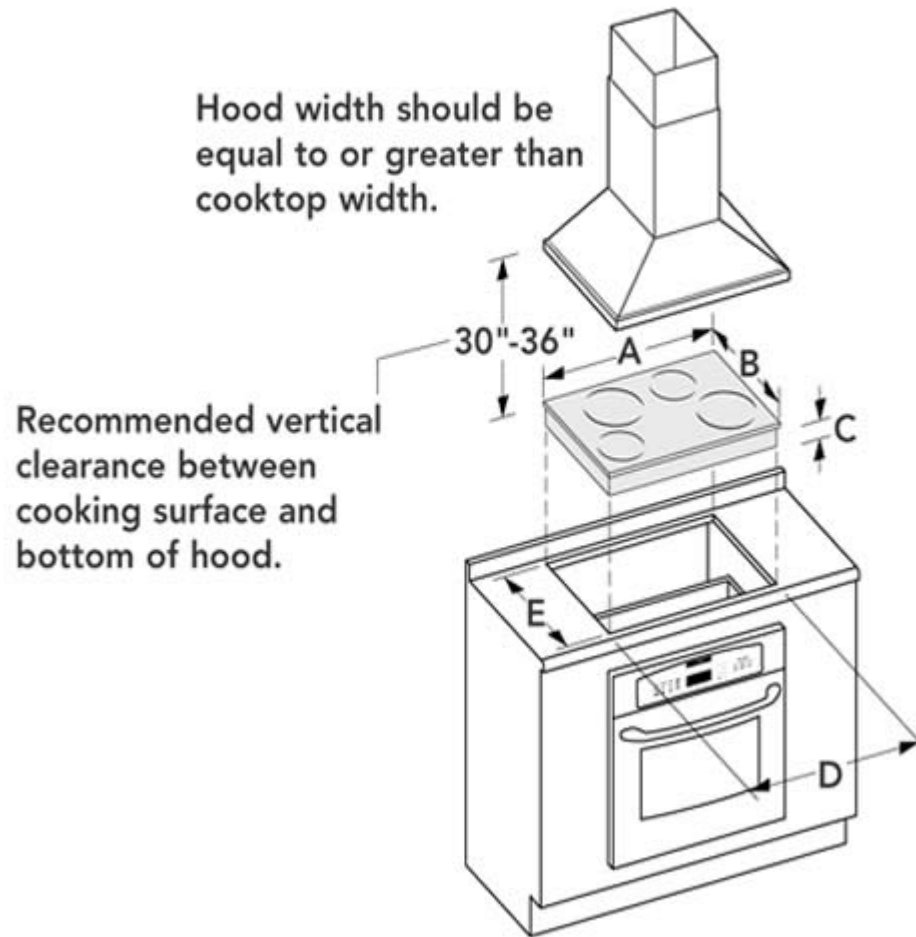

[Click Here to View Features](#)

Note: All heights, width and depth dimensions are shown in inches. * Please refer to installation instructions prior to making cutout. Installation instructions are available at www.thermador.com.

Countertop must be 26" wide overall for best fit. When the under cabinet measures 24" front to back (outside dimensions) it must be positioned so the countertop has a 1" overhang. **"BT" (Backsplash Thickness) = 0

Special Notes:

The countertop must have a 25" flat area so no problems can occur with a backsplash. Important to measure it from the front edge of the countertop. All cutouts start at 2 1/2" from the front edge of the countertop.

Cooktops are UL and CUL approved with the exception of the CEM365, CEM456 and CEP456 which are UL approved only.

[PRINT](#) [CLOSE](#) [EMAIL](#)