

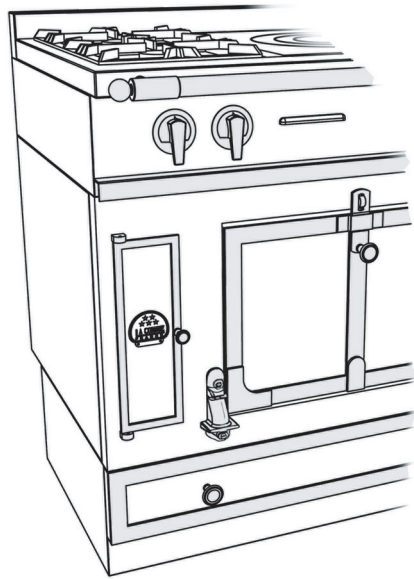

TRIMS

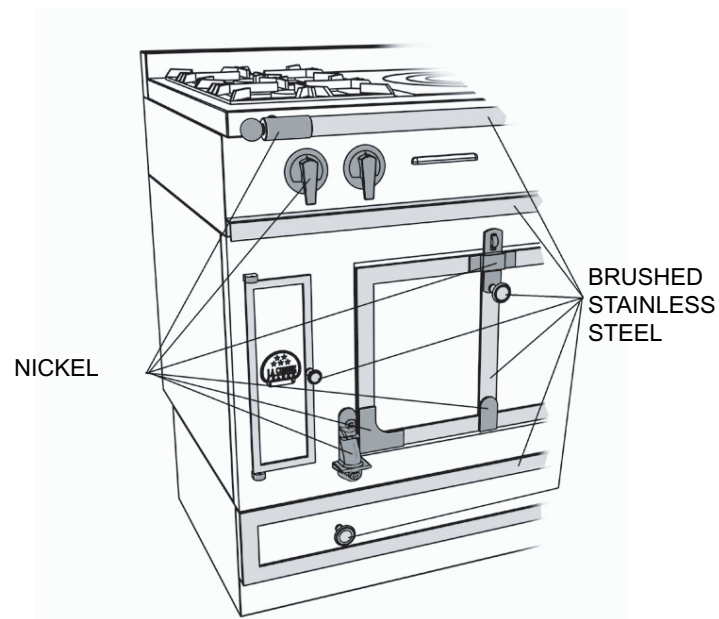

- B** - POLISHED BRASS TRIM
- L** - BRUSHED BRASS TRIM
- K** - POLISHED COPPER TRIM



- N** - BRUSHED STAINLESS STEEL & NICKEL

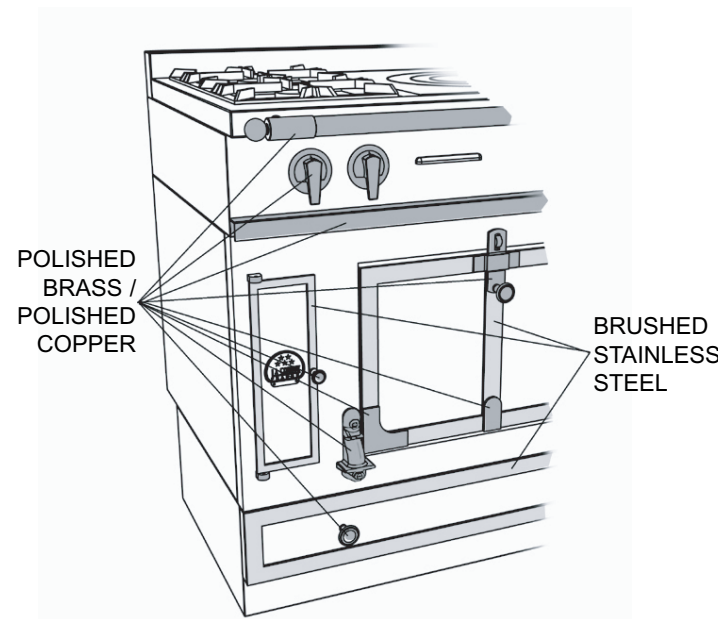

- Y** - POLISHED BRASS & BRUSHED STAINLESS STEEL
- R** - POLISHED COPPER & BRUSHED STAINLESS STEEL

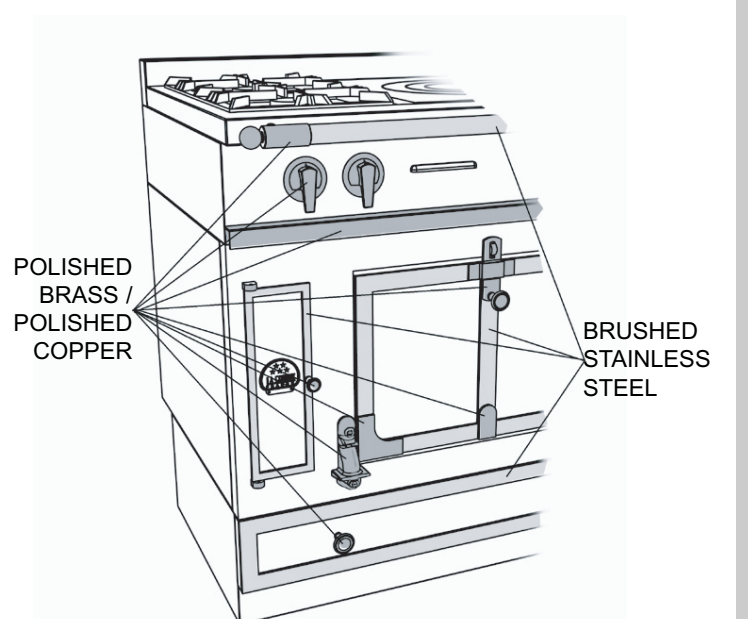

- D** - POLISHED BRASS & BRUSHED STAINLESS STEEL WITH BRUSHED STAINLESS HANDRAIL
- V** - POLISHED COPPER & BRUSHED STAINLESS STEEL WITH BRUSHED STAINLESS HANDRAIL

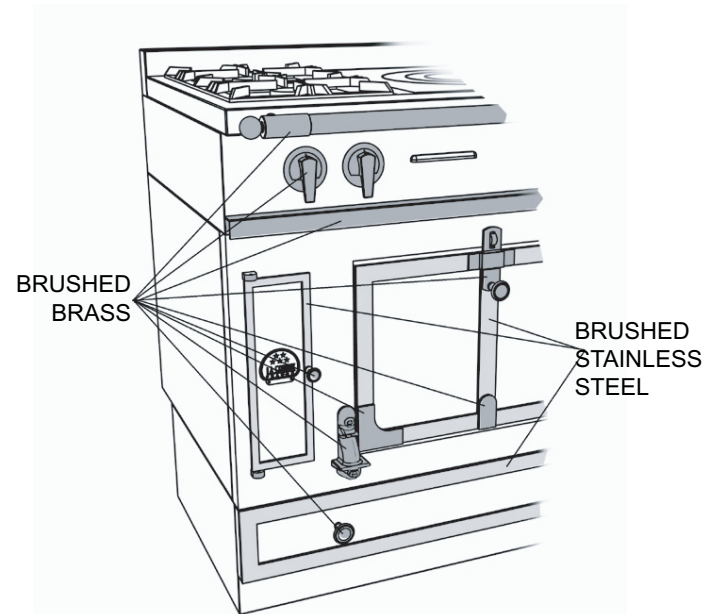

- S** - BRUSHED BRASS AND STAINLESS STEEL

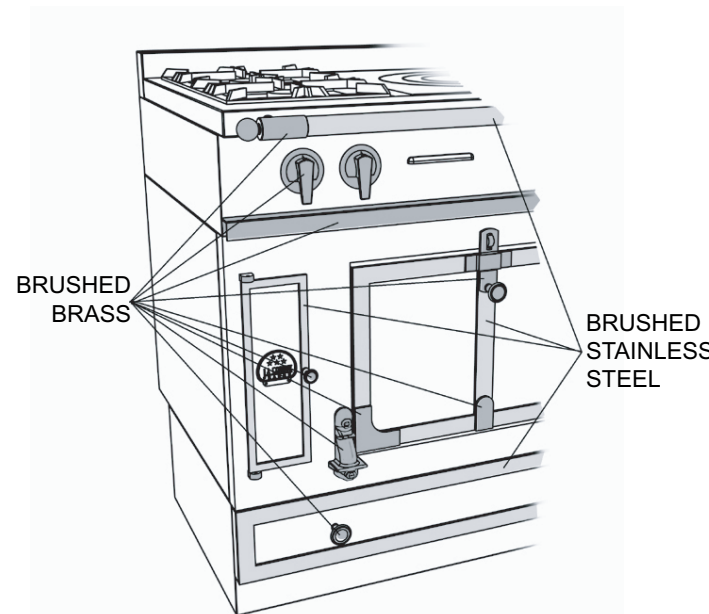

- A** - BRUSHED BRASS AND STAINLESS STEEL WITH BRUSHED STAINLESS HANDRAIL

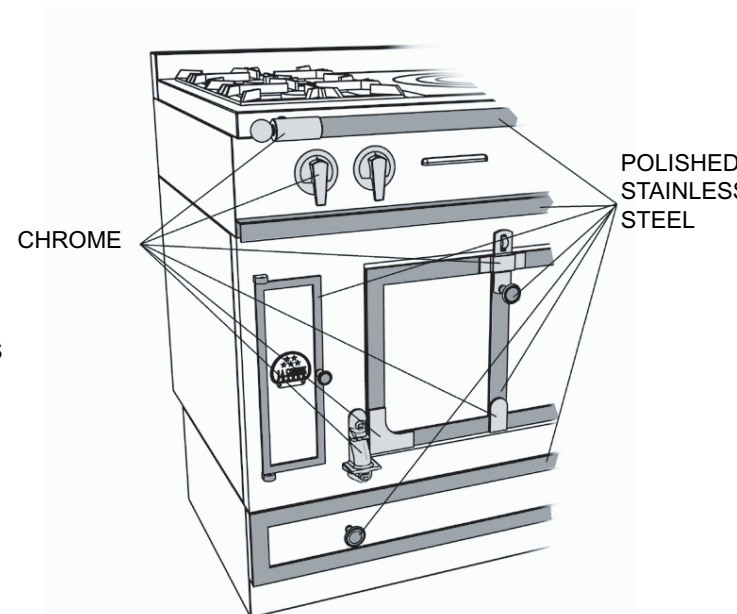

- C** - CHROME & POLISHED STAINLESS STEEL

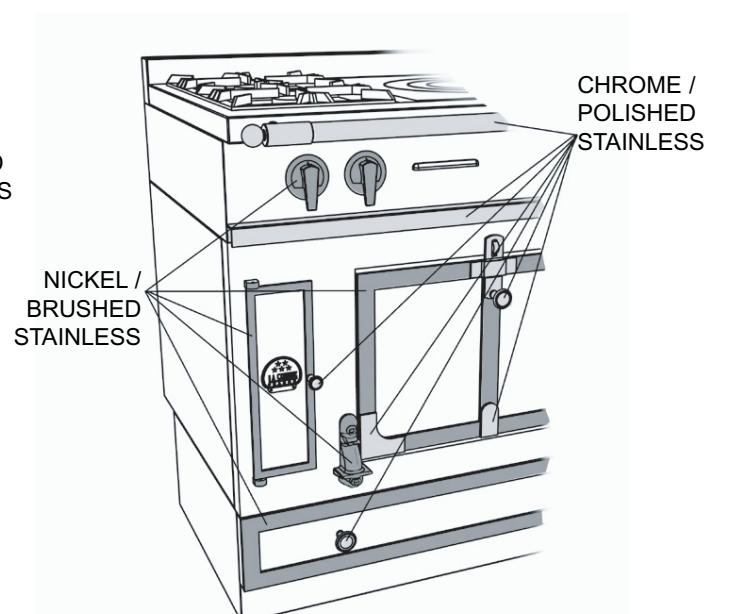

- M** - NICKEL/BRUSHED STAINLESS & CHROME/POLISHED STAINLESS