

**FUEGO**



Most designers wouldn't dream of playing with fire. Fortunately, we're not most designers.

## Where Revolution Trumps Evolution

An outdoor kitchen island. A campfire for modernists. A social magnet with a great sense of style. Attaching a label to Fuego is trickier than throwing a salmon—wild, rubbed with herbs and spices—on an open flame. Yes, Fuego is a grill. But it's a grill without equal. Vibrantly designed with enough technological innovations to satisfy the most left-brained among us, Fuego embodies a revolutionary rethink of outdoor living. Which, for people who prefer their aesthetics well done, is a concept worth embracing.





## Fire Up the Conversation

Let's just say that Fuego has what it takes to throw a great party. Part furniture and part grill, it functions as much as an entertainment hub as a place to prepare a memorable meal. Not content to be sequestered on the sidelines, Fuego takes center stage with a hibachi-style cooking space that encourages guests to stay and hang out. The primary obstacles to interaction such as the mountainous hood have been hidden or redesigned. In their stead is a place to slice, sip and socialize.

## The Advantages of Seeing Double

There are two ways to appreciate Fuego. Literally. Dubbed 01 and 02, the Fuego grills are the opening volleys in the march for modernism. Size is the primary difference between them. 02, our 25" model, tucks neatly on an uptown balcony while 01, our 35" model, is better suited for a rooftop garden or backyard deck. The streamlined functionality, the industrial design aesthetic, the grill-as-gathering-spot concept—those all remain the same. In other words, a Fuego is a Fuego on any scale.





## Fuego 01: Four Sides of the Story

What you see—and what you don't—is an architectural reinvention of outdoor grilling. A fully retractable lid. Countertops wide enough for food, glasses and elbows. Heavy-duty storage areas tucked out of sight. Multiple fuel options. Smooth-wheeling agility. Fuego 01 delivers it all. And then some.



Front



Top

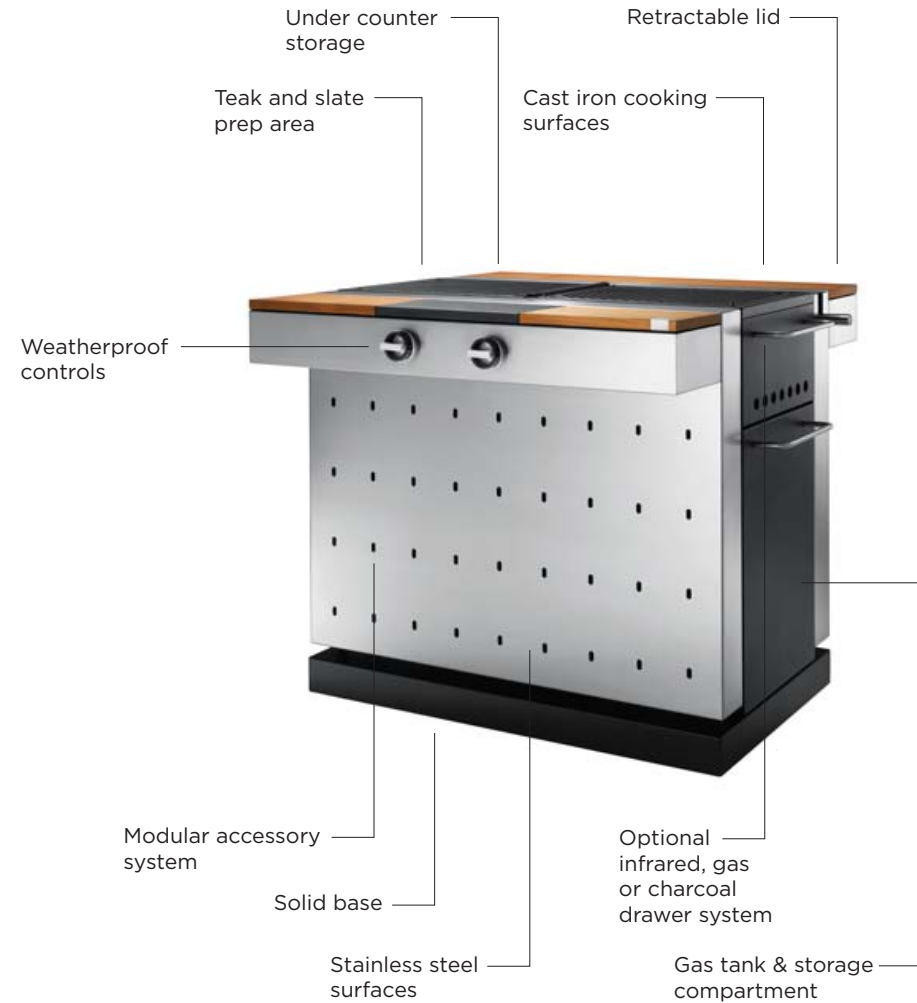

# Fuego 01: Make Room for Modernism

While we've done everything possible to win a place in your heart, let's make sure you actually have room for us.

## Features

- Patented quick change drawer system
- Multiple fuel options
- Fully retractable weather lid
- Teak and slate countertops with hidden storage
- Modular accessory system
- Two sliding drawers for propane tank and storage
- Built-in residue trays
- Battery ignition
- Built-in wheels for easy mobility

## Burner Options

- 2 standard gas drawers 37,000 BTU/hr. FG01AMG
- Optional infrared drawer 18,500 BTU/hr.\* FA01AID
- Optional charcoal drawer\* FA01ACD
- Natural gas conversion available\* FA00AGC

\*Sold as accessory

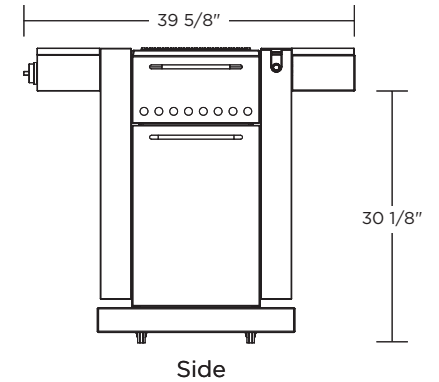
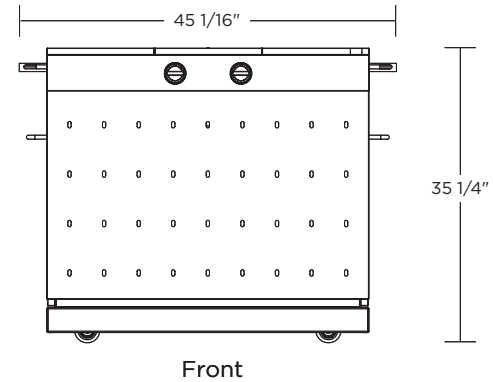
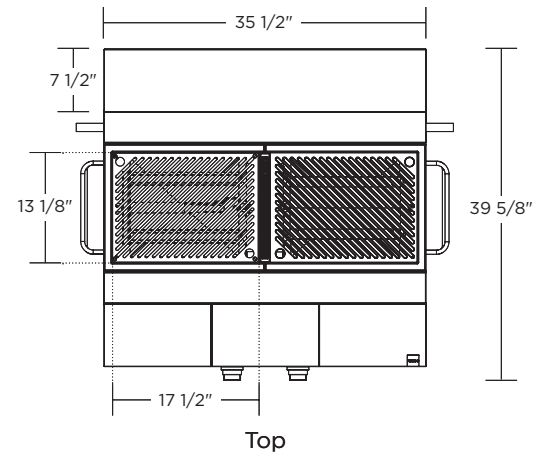

## Fuego 02: Squaring Off the Possibilities

Fuego 02 is a scaled-down interpretation of Fuego 01. It possesses the same signature features as its larger sibling. Teak and slate countertops for prepping food and stirring margaritas. Trays pegged on the side. A hidden storage area. They're all here.



Front



Top

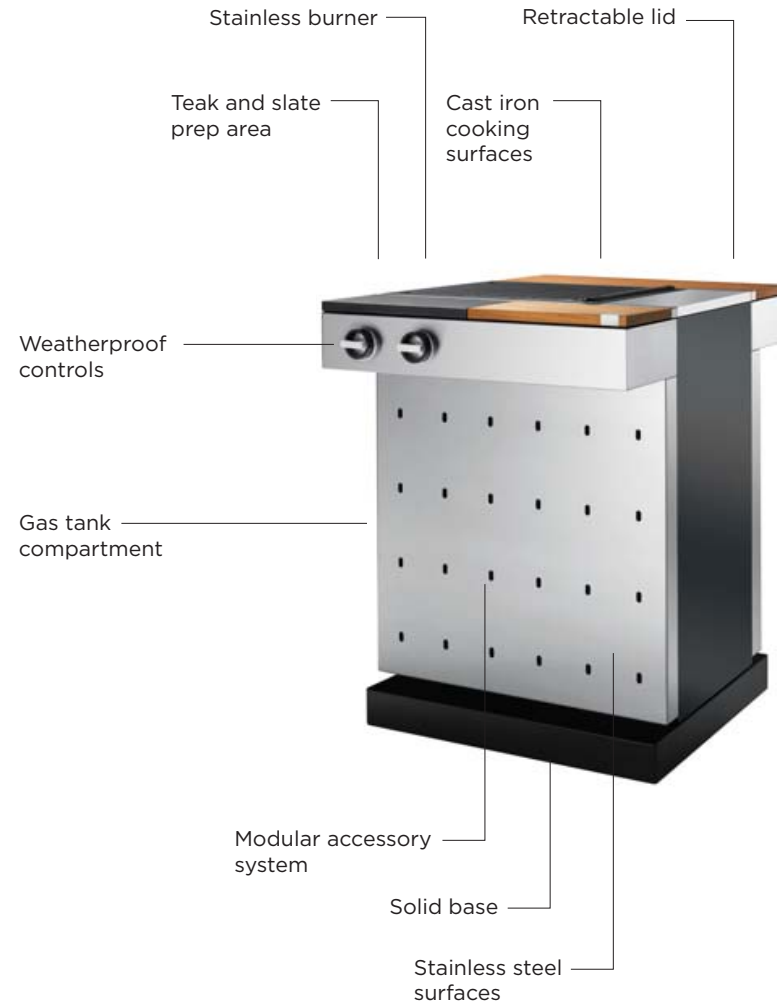

## Fuego 02: Scaled to Size

Know the old adage that good things come in small packages? How true it is.

### Features

- Gas or infrared fuel option
- Fully retractable weather lid
- Slate and teak countertops with hidden storage
- Modular accessory system
- Sliding drawer for propane tank
- Built-in residue trays
- Battery ignition
- Built-in wheels for easy mobility

### Burner Options

- Stainless gas burner 18,500 BTU/hr. FG02AMG
- Infrared burner 18,500 BTU/hr. FG02AMI
- Natural gas conversion available\* FA00AGC

\*Sold as accessory

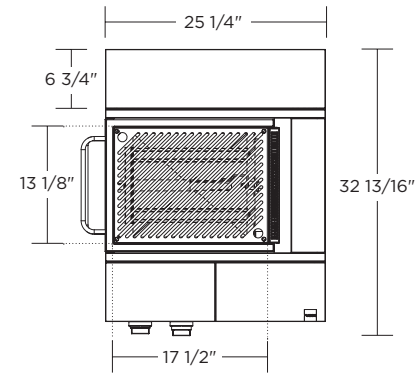

Top

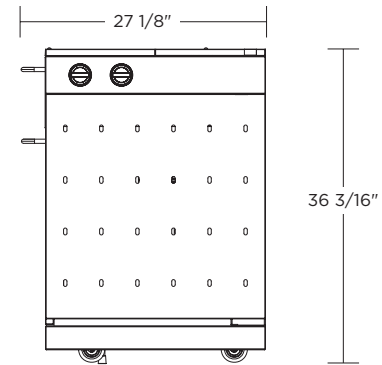

Front

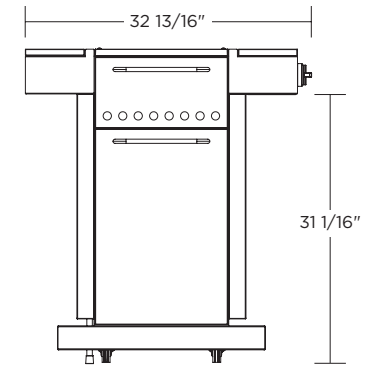

Side

## Up Close

Like everything else in life, details matter. What you'll find with Fuego is modernism executed with the finest materials and technologies.

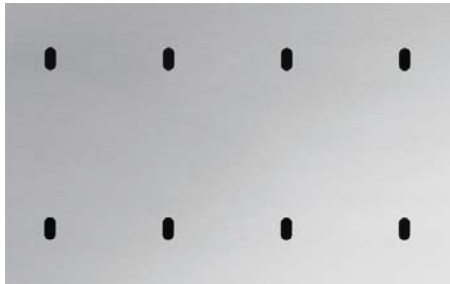

### Modular Accessory System

Geometric slots cut into stainless steel provide the ultimate in functionality, allowing you to peg optional accessories onto the side panels such as stackable food trays, spice jars, storage bins and more.



### Natural Wood Prep Area

Farmed teak countertops on both sides of the grill and a slate insert give the chef and guests enough work space to prep on site. Chop, stir and converse without having to dash back and forth to the kitchen for utensils and ingredients.



### Patented Quick Change Drawer System

Beneath the cast iron grilling surface of Fuego 01 is a patented quick-change drawer system that gives you the freedom to switch from gas to charcoal cooking on the fly. The gas function incorporates the latest in infrared burner technology.



### Retractable Lid

Mountainous hood? What mountainous hood? Fuego has a fully retractable lid that glides into and out of the grill with ease, cleverly doing away with social barriers in seconds flat.



Industrial designer Robert Brunner is famous for challenging the status quo with designs that are fresh and unexpected. His Fuego grill is no exception. Brunner, whose award winning works are included in the permanent collections of the Museum of Modern Art in both New York and San Francisco, is former Director of Design at Apple and partner at internationally renowned Pentagram Design. He is now CEO of Ammunition, a new product design consultancy group focused on keeping innovation red-hot.

[www.fuegoliving.com](http://www.fuegoliving.com)

FUEGO North America  
Roundhouse One  
1500 Sansome Street, #100  
San Francisco, CA 94111  
1.888.88.FUEGO